

# U S E R ' S M A N U A L

## ACTIVE MODULE CARRIER

MODEL  
VX402C-64

## COPYRIGHT

C&H Technologies, Inc. (C&H) provides this manual "as is" without warranty of any kind, either expressed or implied, including but not limited to the implied warranties of merchantability and fitness for a particular purpose. C&H may make improvements and/or changes in the product(s) and/or program(s) described in this manual at any time and without notice.

This publication could contain technical inaccuracies or typographical errors. Changes are periodically made to the information herein; these changes will be incorporated in new editions of this publication.

**Copyright © 2002, 2008 by C&H Technologies, Inc.**

The information and/or drawings set forth in this document and all rights in and to inventions disclosed herein which might be granted thereon disclosing or employing the materials, methods, techniques or apparatus described herein, are the exclusive property of C&H Technologies, Inc.

A Reader's Comment Form is provided at the back of this publication. If this form has been removed address comments to:

C&H Technologies, Inc.  
Technical Publications  
445 Round Rock West Drive  
Austin, Texas 78681-5012

Or visit our web site for support information at:

<http://www.chtech.com>.

C&H may use or distribute any of the information you supply in any way that it believes appropriate without incurring any obligations.

## AMENDMENT NOTICE

C&H Technologies, Inc. makes every attempt to provide up-to-date manuals with the associated equipment. Occasionally, changes are made to the equipment wherein it is necessary to provide amendments to the manual. If any amendments are provided for this manual they are printed on colored paper and will be provided with the module and manual. Manual updates may also be found on our web site at [www.chtech.com](http://www.chtech.com).

### NOTE

The contents of any amendment may affect operation, maintenance, or calibration of the equipment.

## REVISION HISTORY

<u>Rev</u>	<u>Date</u>	<u>Description</u>
*	03-20-2002	Original release
A	09-13-2004	Corrected Figure A-3 (J1) & A-4 (J2) Pin Configurations
B	07-10-2008	Added -0003 and -0004 version information Clarified Electrical information (Section 1.2.2) Clarified Pass-Through Cable information (Section 3.3.3)

## INTRODUCTION

This manual describes the operation and use of the C&H Model VX402C-64 VXI Active Carrier Module (Part Number 11028500 Revision B or higher). This VXI module is one of a number of test and data acquisition/control modules in the VME and VXI format provided by C&H.

Contained within this manual are the physical and electrical specifications, installation and startup procedures, functional description, and configuration guidelines to adequately use the product.

The part numbers covered by this manual are:

<u>Part Number</u>	<u>Description</u>
11028500-0001	VX402C-64 (with +3.3V supplied from VXI +5V)
11028500-0002	VX402C-64 (without +3.3V supply)
11028500-0003	VX402C-64 (with +3.3V supplied from VXI -24V)
11028500-0004	VX402C-64 (with +3.3V supplied from VXI +24V)

## TABLE OF CONTENTS

1.0 GENERAL DESCRIPTION .....	7
1.1 PURPOSE OF EQUIPMENT.....	7
1.2 SPECIFICATIONS OF EQUIPMENT.....	8
1.2.1 Key Features .....	8
1.2.2 Electrical .....	8
1.2.3 Mechanical.....	10
1.2.4 Environmental.....	10
1.2.5 Bus Compliance .....	10
2.0 INSTALLATION .....	11
2.1 UNPACKING AND INSPECTION .....	11
2.2 HANDLING PRECAUTIONS.....	11
2.3 INSTALLATION .....	11
2.4 PREPARATION FOR RESHIPMENT.....	11
3.0 FUNCTIONAL DESCRIPTION .....	13
3.1 GENERAL .....	13
3.2 TRIGGERS.....	14
3.2.1 TTL TRIGGERS .....	14
3.2.2 ECL TRIGGERS.....	15
3.3 CONNECTORS.....	15
3.3.1 VXI REAR Connectors.....	15
3.3.2 VME-64 FRONT CONNECTORS.....	15
3.3.3 PASS-THROUGH CONNECTORS .....	16
3.4 SUMBUS CONFIGURATION .....	18
3.4.1 SUMBUS CUSTOM AREA .....	18
3.4.2 SUMBUS JUMPER SETTINGS.....	19
4.0 OPERATING INSTRUCTIONS .....	21
APPENDIX A - CONNECTORS.....	A-1

## LIST OF FIGURES

Figure 1. Front Panel and Top View (Top Shield Not Shown) .....	7
Figure 2. Power Schematic (-0001 version).....	8
Figure 3. Power Schematic (-0002 version).....	9
Figure 4. Power Schematic (-0003 & -0004 versions).....	9
Figure 5. Functional Block Diagram .....	13
Figure 6. TTL Trigger Direction.....	14
Figure 7. ECL Trigger Direction .....	15
Figure 8. Pass-Through Connector Location .....	16
Figure 9. SUMBUS Custom Area.....	18
Figure 10. SUMBUS Jumper Settings.....	19

## LIST OF TABLES

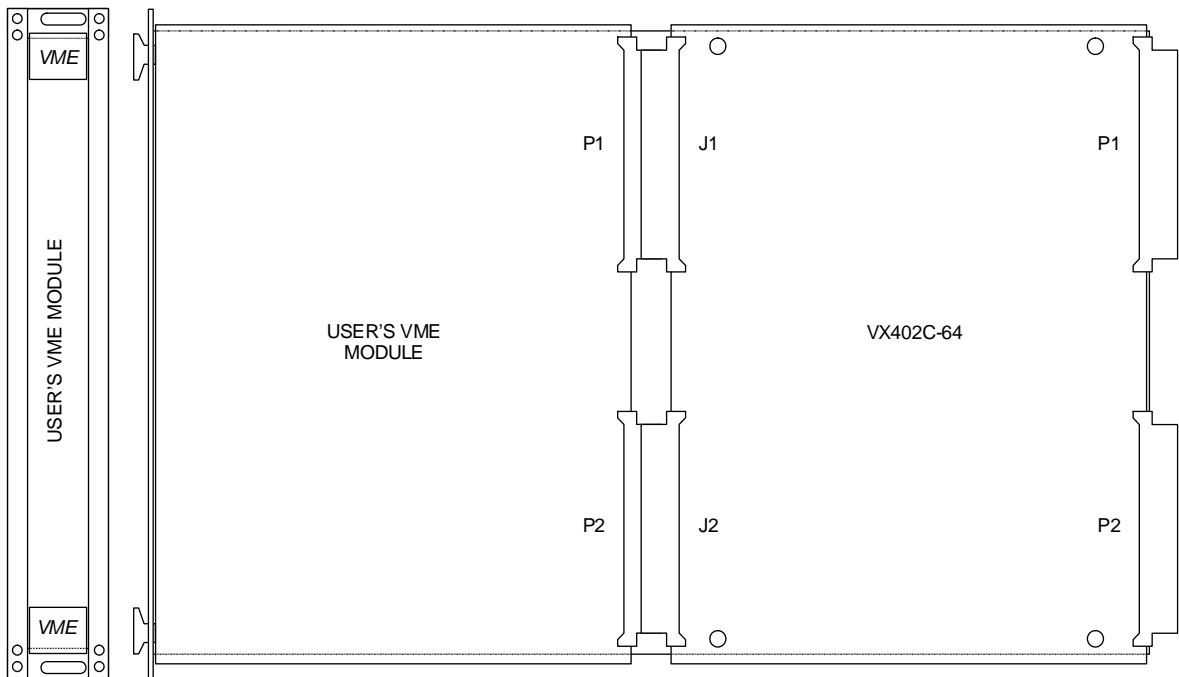
Table I. Power Supply Capabilities.....	10
Table II. VXI/VME Pass-Through Connections .....	17

## 1.0 GENERAL DESCRIPTION

The VX402C-64 Active Carrier allows an A- or B-size VME, VXI, or VME64 module to be used in a C-size VXI mainframe chassis. Throughout the rest of this manual, the VME/VXI card being carried will be referred to as the VME module.

The carrier provides an actively-buffered electrical interface for the standard VME bus signals. The VX402C-64 does not support the full VME64 extension bus; however, -0001, -0003, and -0004 versions provide +3.3V power to the P1 row D VME64 extension. The adapter also features a VXI C-size mechanical enclosure to support and shield the VME module. The carrier and its enclosure have been designed so that the front panel of the VME module sits flush with the front panels of other C-size modules as shown in Figure 1.

The VX402C-64 supports interrupts and provides a capability for bringing P2 VME signals to the front panel. The carrier also supports VXI VXITTL triggers and a prototype area is provided for buffering the VXI SUMBUS signal. These features allow the VME module to transparently interface to a C-size chassis.



**Figure 1. Front Panel and Top View (Top Shield Not Shown)**

### 1.1 PURPOSE OF EQUIPMENT

This VX402C-64 was designed to provide an interface for using B-size VME modules in a VXI C-size chassis. The active nature of the module allows extensions of the VXI bus without violation of VME/VXI electrical bus standards.

## 1.2 SPECIFICATIONS OF EQUIPMENT

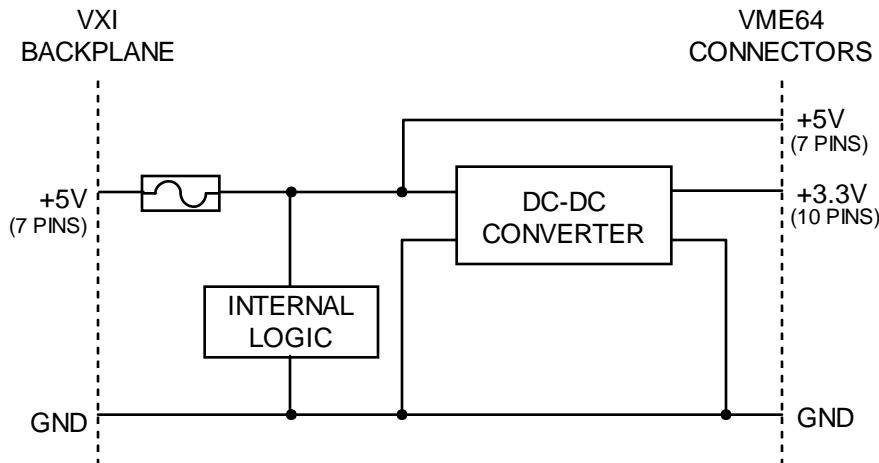
### 1.2.1 Key Features

- Provides direct access to the VME module's front panel I/O connections
- Supplies buffered data, address, interrupt, and trigger lines (ECL and TTL)
- Includes direct SUMBUS connections, as well as a prototyping area with fused  $\pm 12\text{V}$  power supplies for buffered SUMBUS connections (jumper selectable)
- Conforms with VMEbus/VXIbus driving and loading specifications
- Provides VME64 +3.3V supplies (-0001, -0003, and -0004 versions only)
- Mates with VXI, VME, and VME64 rear connectors

### 1.2.2 Electrical

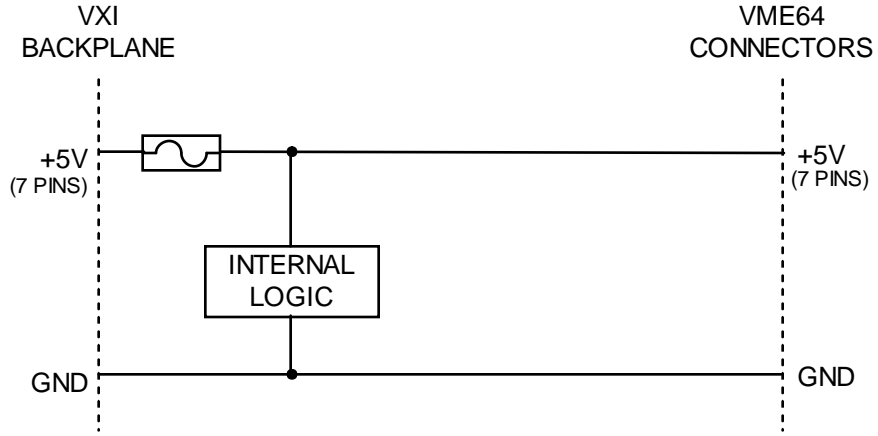
The -0001, -0003, and -0004 versions provide +3.3V power to the P1 row D VME64 extension. The -0002 version does not provide +3.3V power. A simplified power schematic for each version is shown in Figure 2, Figure 3, and Figure 4. Excluding the +3.3V supply, the VX402C-64 only requires 300mA of +5V power from the VXI backplane. This power requirement is for the VX402C-64 alone. Any attached module will increase this value by the amount specified in its data sheet.

Table I provides a summary of the supply capabilities of each version. The table assumes that the VXI backplane is capable providing 1.2A on each of the seven +5V power pins. For versions -0003 and -0004, 1.2A on the -24V and +24V pins.

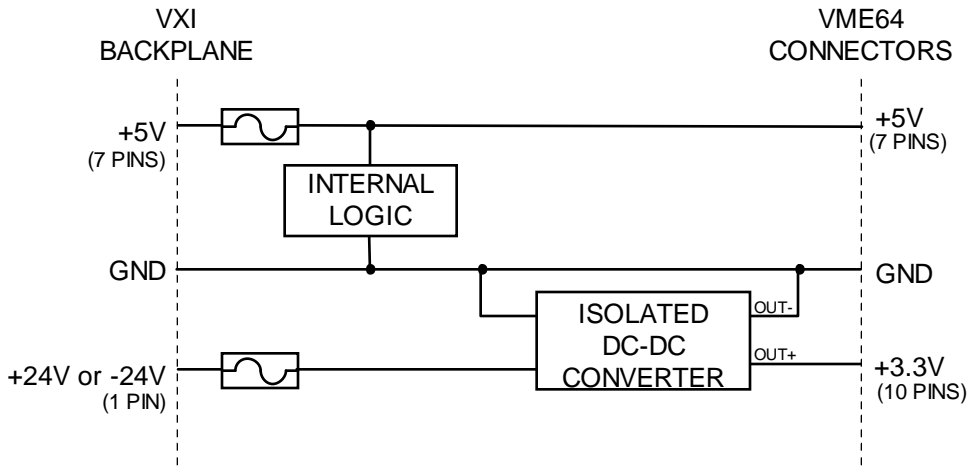


**Figure 2. Power Schematic (-0001 version)**





**Figure 3. Power Schematic (-0002 version)**



**Figure 4. Power Schematic (-0003 & -0004 versions)**

**Table I. Power Supply Capabilities**

	VX402C-64 Version			
	-0001	-0002	-0003	-0004
VXI +5V Supply Capability	42.0W	42.0W	42.0W	42.0W
VXI +24V Supply Capability	not used	not used	not used	29W
VXI -24V Supply Capability	not used	not used	29W	not used
Internal +5V Power Consumption	1.5W	1.5W	1.5W	1.5W
Remaining +5V Power Available	40.5W	40.5W	40.5W	40.5W
+3.3V Converter Efficiency	92%	n/a	80%	80%
+5V Power Available to VME Module	37W Total	40.5W	40.5W	40.5W
+3.3V Power Available to VME Module		0W	23W	23W

n/a = not applicable

### 1.2.3 Mechanical

The mechanical dimensions of the VX402C-64 are in conformance with the VXI bus specification for the height and width of Size-C modules. The nominal dimensions are 233.35 mm (9.187 in) high x 156.337 mm (6.155 in) deep. Once the VX402C-64 is adapted to a VME module, the total dimensions are 233.35 mm (9.187 in) high x 340.0 mm (13.386 in) deep. The module is designed for a mainframe with 30.48 mm (1.2 in) spacing between slots.

### 1.2.4 Environmental

The environmental specifications of the module are:

Operating Temperature: 0°C to +55°C  
Storage Temperature: -40°C to +75°C  
Humidity: <95% without condensation

### 1.2.5 Bus Compliance

The module complies with the VXIbus Specification Revision 1.4 and with VMEbus Specification ANSI/IEEE STD 1014-1987, IEC 821 and IEC 822.

Module: VME to VXI Extender  
Device Type: Active Carrier

## 2.0 INSTALLATION

### 2.1 UNPACKING AND INSPECTION

In most cases the VX402C-64 is individually sealed and packaged for shipment. Verify that there has been no damage to the shipping container. If damage exists then the container should be retained as it will provide evidence of carrier caused problems. Such problems should be reported to the carrier immediately as well as to C&H. If there is no damage to the shipping container, carefully remove the module from its box and anti static bag and inspect for any signs of physical damage. If damage exists, report immediately to C&H.

### 2.2 HANDLING PRECAUTIONS

The VX402C-64 contains components that are sensitive to electrostatic discharge. When handling the module for any reason, do so at a static-controlled workstation, whenever possible. At a minimum, avoid work areas that are potential static sources, such as carpeted areas. Avoid unnecessary contact with the components on the module.

### 2.3 INSTALLATION

**CAUTION: Read the entire User's Manual before proceeding with the installation and application of power.**

If necessary, remove the shield from the VX402C-64 and configure the switches and jumpers. Replace the shield and insert the carrier into the appropriate slot according to the desired priority. Insert the VME module through the front panel of the VX402C-64. Push firmly until the VME module's rear connectors are fully inserted into the front connector of the VX402C-64. Apply power. If no obvious problems exist, proceed to communicate with the VME module.

The VX402C-64 connectors require high insertion force to completely connect with the VME module. If it is difficult to assemble the unit through the front panel, it is recommended that the VX402C-64 shield be removed, and the boards be mated before insertion into the chassis.

### 2.4 PREPARATION FOR RESHIPMENT

If the module is to be shipped separately it should be enclosed in a suitable water and vapor proof anti static bag. Heat seal or tape the bag to insure a moisture-proof closure. When sealing the bag, keep trapped air volume to a minimum.

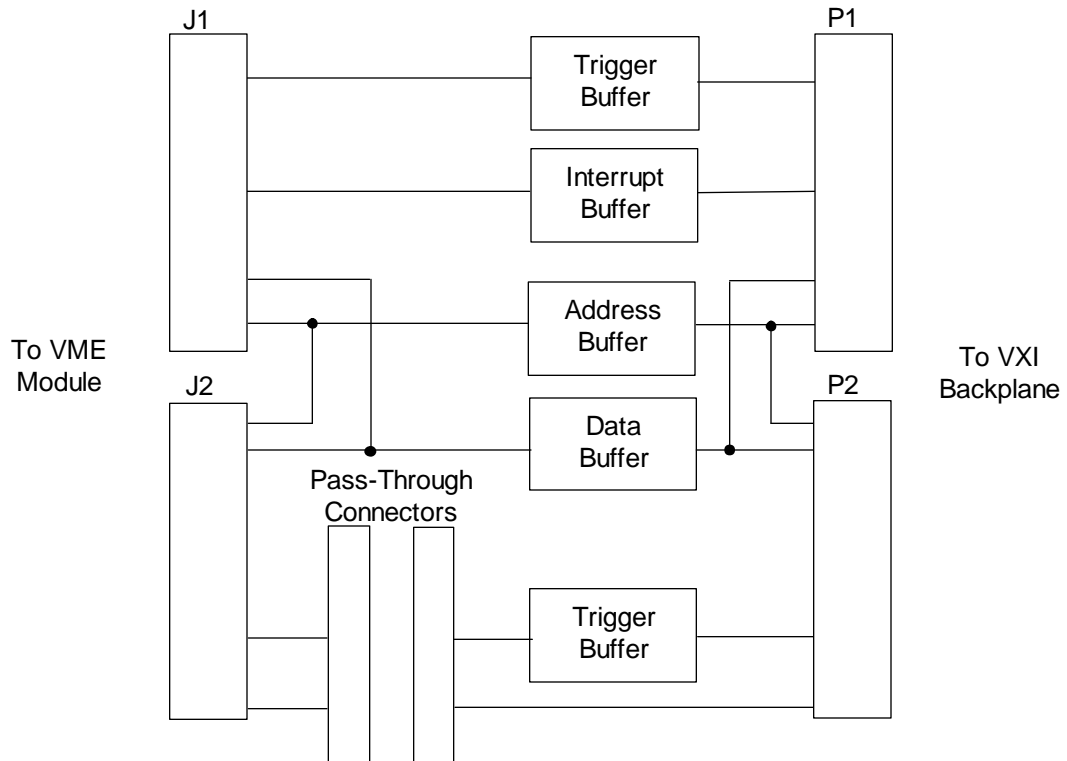
The shipping container should be a rigid box of sufficient size and strength to protect the equipment from damage. If the module was received separately from a C&H system, then the original module shipping container and packing material may be re-used if it is still in good condition.



### 3.0 FUNCTIONAL DESCRIPTION

#### 3.1 GENERAL

VX402C-64 is a general purpose carrier module for VXI C-Size chassis. The module provides actively buffered signals, which meet all VME specifications, to the VME module. A functional block diagram is shown in Figure 5.



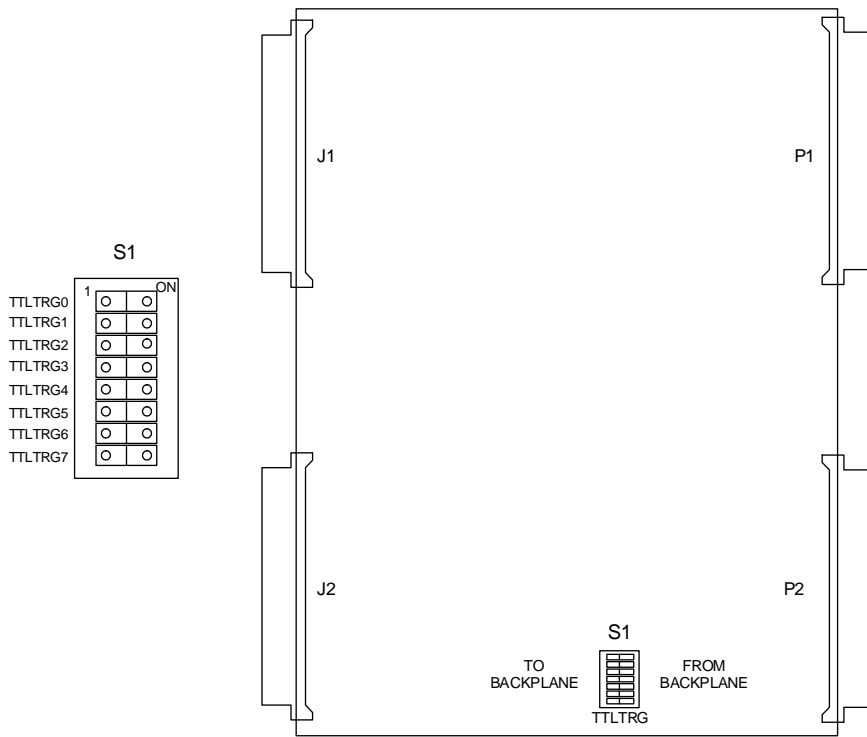
**Figure 5. Functional Block Diagram**

### 3.2 TRIGGERS

Both ECL and TTL triggers are supplied through the VX402C-64. There are switches on the carrier which are used to set the direction of the triggers (to the backplane and from the backplane).

#### 3.2.1 TTL TRIGGERS

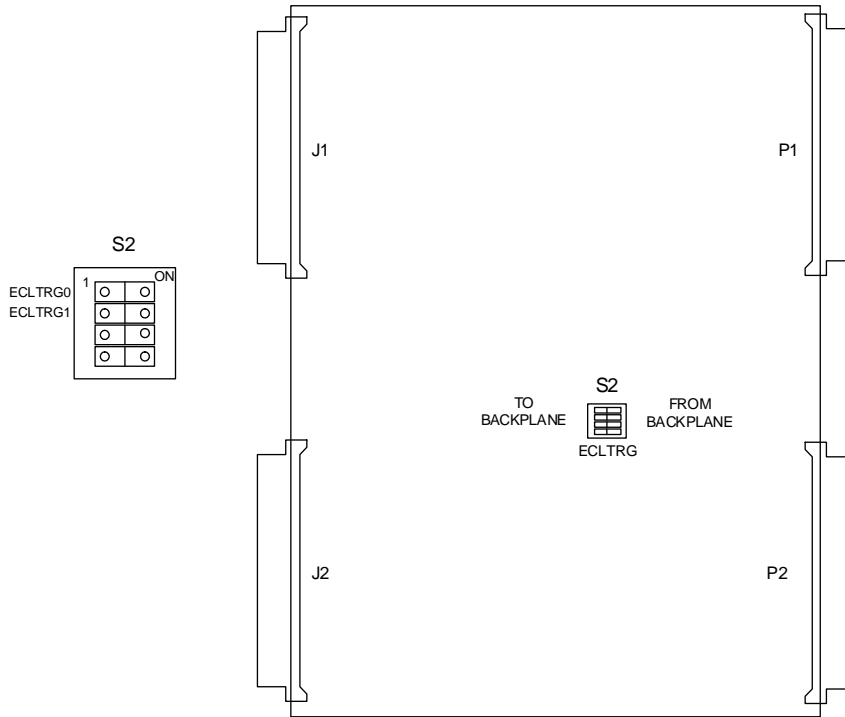
Eight TTL Trigger lines pass through the VX402C-64 to the front panel: TTLTRG0-7. Each trigger line may be set as an input or output trigger. The trigger direction is set using switch S1 which can be seen in Figure 6. The directions are also clearly marked on the board itself.



**Figure 6. TTL Trigger Direction**

### 3.2.2 ECL TRIGGERS

The VX402C-64 supports two ECL Trigger lines: ECLTRG0-1. Each trigger line may be set as an input or output trigger. The trigger direction is set using switch S2 which can be seen in Figure 7. The trigger directions are clearly marked on the board itself.



**Figure 7. ECL Trigger Direction**

### 3.3 CONNECTORS

#### 3.3.1 VXI REAR Connectors

The P1 and P2 connectors are configured in accordance with the VXI specification and utilize the ECL and TTL trigger lines. Pinout details for the rear connectors can be found in Appendix A.

#### 3.3.2 VME-64 FRONT CONNECTORS

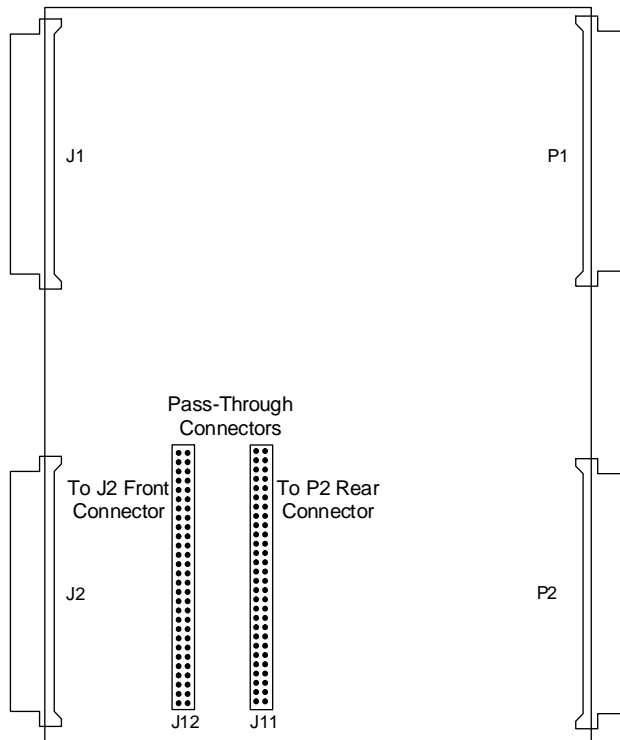
The VX402C-64 interfaces with the VME module through two 160 pin VME-64 connectors: J1 and J2. These connectors conform to VME and VXI specifications and can accept both 160 pin VME-64 (DIN 41 612 type C) and standard 96 pin VME/VXI connectors. Pinout details for the front connectors can be found in Appendix A.

### 3.3.3 PASS-THROUGH CONNECTORS

One major difference between the VME bus and the VXI bus is that the outer rows of the P2 connector are not defined on the VME bus and they are defined on the VXI bus. For this reason, the VX402C-64 Active Module Carrier provides a Pass-Through Connector system that be used to optionally connect or not connect the VME P2 Rows A & C signals to the VXI P2 Rows A & C signals.

The VX402C-64 can be shipped with an optional pass-through connector cable (11028508-0001). This cable is used to make internal connections between the P2 and J2 connectors on the VX402C-64. When the cable is installed, signals on the J2 connector of the VME module are routed to signals on the P2 connector of the backplane. Only use this cable for modules which utilize the outer rows on the J2 connector and completely adhere to the VXI specification. If the VME module has no outer row connections, it is unnecessary to install the cable.

If the VME module has P2 signals which do not conform to the VXI spec, it may be necessary to make a custom pass-through cable. Also, if the VME module does not support the outer row of the J2 connector, a longer cable may be used to directly access these signals. Pinout details for the pass-through connectors can be found in Appendix A. Figure 8 shows the placement of the pass-through connectors on the VX402C-64.



**Figure 8. Pass-Through Connector Location**



A one-to-one cable that connects Pin 1 (C32) on the VXI side to Pin 1 (C32) on the VME side, and so on, could only be used if the VME module was designed to meet all of the VXI bus specifications for these pins. If the installed VME module can not handle -24V, +24V, -5.2V or any other signal on the corresponding pin, then a one-to-one cable can not be used.

The signal list for both the VXI side and the VME side is shown in Table II. The pass-through connectors on the PCB are standard 64-pin (32x2) shrouded headers, specifically Samtec TST-132-01-S-D. Mating connectors are very common in both IDC and discreet wire varieties.

**Table II. VXI/VME Pass-Through Connections**

VXI SIDE PASS-THROUGH CONNECTOR						VME SIDE PASS-THROUGH CONNECTOR					
PN	P2	SIGNAL	PIN	P2	SIGNAL	PN	P2	SIGNAL	PIN	P2	SIGNAL
1	C32	-24V	2	A32	SUMBUS	1	C32	USER DEF	2	A32	USER DEF
3	C31	+24V	4	A31	GND	3	C31	USER DEF	4	A31	USER DEF
5	C30	GND	6	A30	MODID	5	C30	USER DEF	6	A30	USER DEF
7	C29	RSV3	8	A29	RSV2	7	C29	USER DEF	8	A29	USER DEF
9	C28	GND	10	A28	GND	9	C28	USER DEF	10	A28	USER DEF
11	C27	TTLTRG7*	12	A27	TTLTRG6*	11	C27	USER DEF	12	A27	USER DEF
13	C26	TTLTRG5*	14	A26	TTLTRG4*	13	C26	USER DEF	14	A26	USER DEF
15	C25	GND	16	A25	+5V	15	C25	USER DEF	16	A25	USER DEF
17	C24	TTLTRG3*	18	A24	TTLTRG2*	17	C24	USER DEF	18	A24	USER DEF
19	C23	TTLTRG1*	20	A23	TTLTRG0*	19	C23	USER DEF	20	A23	USER DEF
21	C22	GND	22	A22	GND	21	C22	USER DEF	22	A22	USER DEF
23	C21	LBUSC11	24	A21	LBUSA11	23	C21	USER DEF	24	A21	USER DEF
25	C20	LBUSC10	26	A20	LBUSA10	25	C20	USER DEF	26	A20	USER DEF
27	C19	-5.2V	28	A19	-5.2V	27	C19	USER DEF	28	A19	USER DEF
29	C18	LBUSC09	30	A18	LBUSA09	29	C18	USER DEF	30	A18	USER DEF
31	C17	LBUSC08	32	A17	LBUSA08	31	C17	USER DEF	32	A17	USER DEF
33	C16	GND	34	A16	GND	33	C16	USER DEF	34	A16	USER DEF
35	C15	LBUSC07	36	A15	LBUSA07	35	C15	USER DEF	36	A15	USER DEF
37	C14	LBUSC06	38	A14	LBUSA06	37	C14	USER DEF	38	A14	USER DEF
39	C13	-2V	40	A13	-5.2V	39	C13	USER DEF	40	A13	USER DEF
41	C12	LBUSC05	42	A12	LBUSA05	41	C12	USER DEF	42	A12	USER DEF
43	C11	LBUSC04	44	A11	LBUSA04	43	C11	USER DEF	44	A11	USER DEF
45	C10	GND	46	A10	GND	45	C10	USER DEF	46	A10	USER DEF
47	C9	LBUSC03	48	A9	LBUSA03	47	C9	USER DEF	48	A9	USER DEF
49	C8	LBUSC02	50	A8	LBUSA02	49	C8	USER DEF	50	A8	USER DEF
51	C7	GND	52	A7	-5.2V	51	C7	USER DEF	52	A7	USER DEF
53	C6	LBUSC01	54	A6	LBUSA01	53	C6	USER DEF	54	A6	USER DEF
55	C5	LBUSC00	56	A5	LBUSA00	55	C5	USER DEF	56	A5	USER DEF
57	C4	-5.2V	58	A4	GND	57	C4	USER DEF	58	A4	USER DEF
59	C3	GND	60	A3	ECLTRG1	59	C3	USER DEF	60	A3	USER DEF
61	C2	CLK10-	62	A2	-2V	61	C2	USER DEF	62	A2	USER DEF
63	C1	CLK10+	64	A1	ECLTRG0	63	C1	USER DEF	64	A1	USER DEF

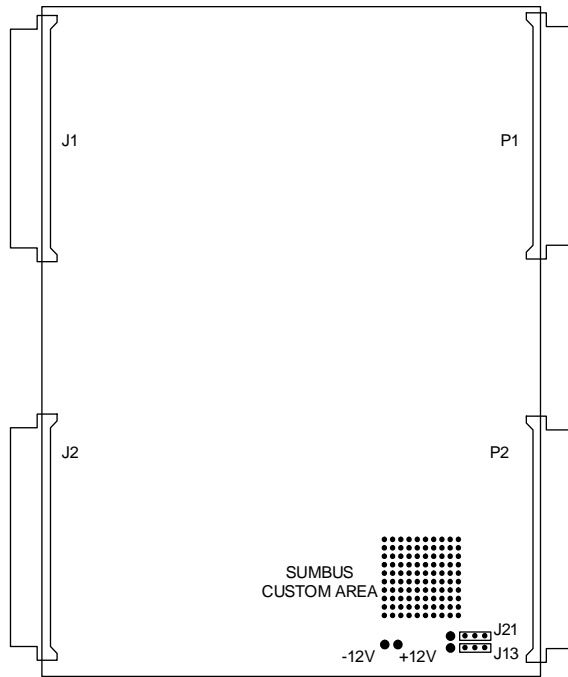
To use the VXI TTLTRG signals, a custom cable should be used that connects each TTLTRG signal to the desired VME P2 connector signal. The VX402C-64 has a set of eight switches that are set to specify the direction of the trigger signal as shown Figure 6. If the trigger signal is an input to the VME module, the switch should be ON (closed). If the trigger signal is output from the VME module, the switch should be OFF (open).

### 3.4 SUMBUS CONFIGURATION

The VX402C-64 provides a direct connection of the SUMBUS signal through the pass-through connector to the front connectors. The board also has a prototyping area so that the user can hardwire a custom buffer for the SUMBUS signal.

#### 3.4.1 SUMBUS CUSTOM AREA

The SUMBUS custom area consists of a prototyping grid,  $\pm 12V$  supplies, and two jumpers for configuring the signal. The prototyping area is a 10x10 grid of 0.1" spaced through-hole pads which can be used in any way desired. The SUMBUS signal can be wired to the prototyping area using the two pads next to jumpers J21 and J13, and the jumpers must be configured to the proper setting. The location of the custom area can be seen in Figure 9.

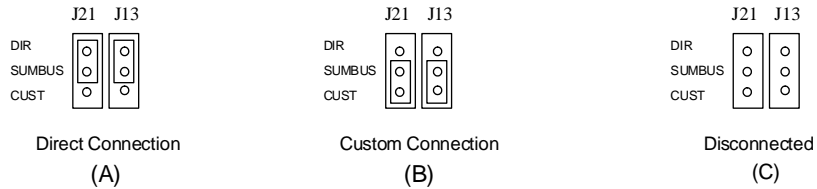


**Figure 9. SUMBUS Custom Area**

### 3.4.2 SUMBUS JUMPER SETTINGS

In order to use the SUMBUS signal, the jumpers J11 and J12 must be configured properly. The three different settings for the jumpers can be seen in Figure 10. The SUMBUS signal can be connected directly to the front panel (A), connected through the prototyping area (B), or disconnected (C).

The pass-through connector must be installed for the SUMBUS signal to route to the front panel. Also, both jumpers must be configured the same, or the SUMBUS signal will be disconnected.



**Figure 10. SUMBUS Jumper Settings**



## 4.0 OPERATING INSTRUCTIONS

While the VX402C-64 is an active carrier, it is designed to be completely transparent to the host interface. For this reason, the VME module can be accessed as if it were plugged directly into the host backplane.

In order to operate the VME module, first set up the hardware configurations on the VX402C-64. Then set the necessary trigger directions using the switches. Ensure the jumpers are set for proper SUMBUS signal routing. Install or remove the pass-through connector cable as desired and replace the shield if necessary.

The unit is now ready to be inserted into the chassis. Next, install the VME module into the front connectors of the VX402C-64. Once power is applied, the VME module can be readily accessed as if it were plugged directly in the backplane.



## APPENDIX A - CONNECTORS

PIN	C	B	A
1	D08	-	D00
2	D09	-	D01
3	D10	ACFAIL*	D02
4	D11	BGIN0*	D03
5	D12	BGOUT0*	D04
6	D13	BGIN1*	D05
7	D14	BGOUT1*	D06
8	D15	BGIN2*	D07
9	GND	BGOUT2*	GND
10	SYSFAIL*	BGIN3*	SYSCLK
11	BERR*	BGOUT3*	GND
12	SYSRESET*	-	DS1*
13	LWORD*	-	DS0*
14	AM5	-	WRITE*
15	A23	-	GND
16	A22	AM0	DTACK*
17	A21	AM1	GND
18	A20	AM2	AS*
19	A19	AM3	GND
20	A18	GND	IACK*
21	A17	-	IACKIN*
22	A16	-	IACKOUT*
23	A15	GND	AM4
24	A14	IRQ7*	A07
25	A13	IRQ6*	A06
26	A12	IRQ5*	A05
27	A11	IRQ4*	A04
28	A10	IRQ3*	A03
29	A09	IRQ2*	A02
30	A08	IRQ1*	A01
31	+12 V	+5VSTBY	-12 V
32	+5 V	+5 V	+5 V

**Figure A-1. P1 Pin Configuration**

NOTE: BGINx tied directly to BGOUTx

PIN	C	B	A
1	CLK10+	+5V	ECLTRG0
2	CLK10-	GND	-2V
3	GND	RSV1	ECLTRG1
4	-5.2V	A24	GND
5	LBUSC00	A25	LBUSA00
6	LBUSC01	A26	LBUSA01
7	GND	A27	-5.2V
8	LBUSC02	A28	LBUSA02
9	LBUSC03	A29	LBUSA03
10	GND	A30	GND
11	LBUSC04	A31	LBUSA04
12	LBUSC05	GND	LBUSA05
13	-2V	+5V	-5.2V
14	LBUSC06	D16	LBUSA06
15	LBUSC07	D17	LBUSA07
16	GND	D18	GND
17	LBUSC08	D19	LBUSA08
18	LBUSC09	D20	LBUSA09
19	-5.2V	D21	-5.2V
20	LBUSC10	D22	LBUSA10
21	LBUSC11	D23	LBUSA11
22	GND	GND	GND
23	TTLTRG1*	D24	TTLTRG0*
24	TTLTRG3*	D25	TTLTRG2*
25	GND	D26	+5V
26	TTLTRG5*	D27	TTLTRG4*
27	TTLTRG7*	D28	TTLTRG6*
28	GND	D29	GND
29	RSV3	D30	RSV2
30	GND	D31	MODID
31	+24V	GND	GND
32	-24V	+5V	SUMBUS

**Figure A-2. P2 Pin Configuration**



PIN	D	C	B	A	Z
1	-	BD08	-	BD00	-
2	GND	BD09	-	BD01	GND
3	-	BD10	BACFAIL*	BD02	-
4	-	BD11	IN0*	BD03	GND
5	-	BD12	OUT0*	BD04	-
6	-	BD13	IN1*	BD05	GND
7	-	BD14	OUT1*	BD06	-
8	-	BD15	IN2*	BD07	GND
9	-	GND	OUT2*	GND	-
10	-	BSYSFAIL*	IN3*	BSYSCLK	GND
11	-	BBERR*	OUT3*	GND	-
12	+3.3V	BSYSRESET*	-	BDS1*	GND
13	-	BLWORD*	-	BDS0*	-
14	+3.3V	BAM5	-	BWRITE*	GND
15	-	BA23	-	GND	-
16	+3.3V	BA22	BAM0	BDTACK*	GND
17	-	BA21	BAM1	GND	-
18	+3.3V	BA20	BAM2	BAS*	GND
19	-	BA19	BAM3	GND	-
20	+3.3V	BA18	GND	BIACK*	GND
21	-	BA17	-	BIACKIN*	-
22	+3.3V	BA16	-	BIACKOUT*	GND
23	-	BA15	GND	BAM4	-
24	+3.3V	BA14	BIRQ7*	BA07	GND
25	-	BA13	BIRQ6*	BA06	-
26	+3.3V	BA12	BIRQ5*	BA05	GND
27	-	BA11	BIRQ4*	BA04	-
28	+3.3V	BA10	BIRQ3*	BA03	GND
29	-	BA09	BIRQ2*	BA02	-
30	+3.3V	BA08	BIRQ1*	BA01	GND
31	GND	+12 V	+5VSTBY	-12 V	-
32	-	+5 V	+5 V	+5 V	GND

**Figure A-3. J1 Pin Configuration**

NOTES:

1. INx tied directly to OUTx.
2. +3.3V supplied on Version -0001 only

PIN	D	C	B	A	Z
1	-	CLK10+n	+5V	BECLTRG0	-
2	-	CLK10-n	GND	-2V2	GND
3	-	GND14	RSV1	BECLTRG1	-
4	-	-5.2V5	BA24	GND13	GND
5	-	LBUSC00n	BA25	LBUSA00n	-
6	-	LBUSC01n	BA26	LBUSA01n	GND
7	-	GND12	BA27	-5.2V4	-
8	-	LBUSC02n	BA28	LBUSA02n	GND
9	-	LBUSC03n	BA29	LBUSA03n	-
10	-	GND10	BA30	GND11	GND
11	-	LBUSC04n	BA31	LBUSA04n	-
12	-	LBUSC05n	GND	LBUSA05n	GND
13	-	-2V1	+5V	-5.2V3	-
14	-	LBUSC06n	BD16	LBUSA06n	GND
15	-	LBUSC07n	BD17	LBUSA07n	-
16	-	GND08	BD18	GND09	GND
17	-	LBUSC08n	BD19	LBUSA08n	-
18	-	LBUSC09n	BD20	LBUSA09n	GND
19	-	-5.2V1	BD21	-5.2V2	-
20	-	LBUSC10n	BD22	LBUSA10n	GND
21	-	LBUSC11n	BD23	LBUSA11n	-
22	-	GND06	GND	GND07	GND
23	-	BTTLTRG1*	BD24	BTTLTRG0*	-
24	-	BTTLTRG3*	BD25	BTTLTRG2*	GND
25	-	GND05	BD26	+5Vn	-
26	-	BTTLTRG5*	BD27	BTTLTRG4*	GND
27	-	BTTLTRG7*	BD28	BTTLTRG6*	-
28	-	GND03	BD29	GND04	GND
29	-	RSV3n	BD30	RSV2n	-
30	-	GND02	BD31	MODIDn	GND
31	GND	+24Vn	GND	GND01	-
32	-	-24Vn	+5V	BSUMBUSn	GND

**Figure A-4. J2 Pin Configuration**

**NOTES:**

1. Signals on Rows A & C are only connected, if the pass-through cable is installed.
2. +3.3V supplied on Version -0001 only

TO FRONT CONNECTOR J2			
PIN		PIN	
1	-24Vn	2	BSUMBUSn
3	+24Vn	4	GND01
5	GND02	6	MODIDn
7	RSV3n	8	RSV2n
9	GND03	10	GND04
11	BTTLTRG7*n	12	BTTLTRG6*n
13	BTTLTRG5*n	14	BTTLTRG4*n
15	GND05	16	+5Vn
17	BTTLTRG3*n	18	BTTLTRG2*n
19	BTTLTRG1*n	20	BTTLTRG0*n
21	GND06	22	GND07
23	LBUSC11n	24	LBUSA11n
25	LBUSC10n	26	LBUSA10n
27	-5.2V1	28	-5.2V2
29	LBUSC09n	30	LBUSA09n
31	LBUSC08n	32	LBUSA08n
33	GND08	34	GND09
35	LBUSC07n	36	LBUSA07n
37	LBUSC06n	38	LBUSA06n
39	-2V1	40	-5.2V3
41	LBUSC05n	42	LBUSA05n
43	LBUSC04n	44	LBUSA04n
45	GND10	46	GND11
47	LBUSC03n	48	LBUSA03n
49	LBUSC02n	50	LBUSA02n
51	GND12	52	-5.2V4
53	LBUSC01n	54	LBUSA01n
55	LBUSC00n	56	LBUSA00n
57	-5.2V5	58	GND13
59	GND14	60	BECLTRG1n
61	CLK10-n	62	-2V2
63	CLK10+n	64	BECLTRG0n

TO REAR CONNECTOR P2			
PIN		PIN	
1	-24V	2	BSUMBUS
3	+24V	4	GND
5	GND	6	MODID
7	RSV3	8	RSV2
9	GND	10	GND
11	BTTLTRG7*	12	BTTLTRG6*
13	BTTLTRG5*	14	BTTLTRG4*
15	GND	16	+5V
17	BTTLTRG3*	18	BTTLTRG2*
19	BTTLTRG1*	20	BTTLTRG0*
21	GND	22	GND
23	LBUSC11	24	LBUSA11
25	LBUSC10	26	LBUSA10
27	-5.2V	28	-5.2V
29	LBUSC09	30	LBUSA09
31	LBUSC08	32	LBUSA08
33	GND	34	GND
35	LBUSC07	36	LBUSA07
37	LBUSC06	38	LBUSA06
39	-2V	40	-5.2V
41	LBUSC05	42	LBUSA05
43	LBUSC04	44	LBUSA04
45	GND	46	GND
47	LBUSC03	48	LBUSA03
49	LBUSC02	50	LBUSA02
51	GND	52	-5.2V
53	LBUSC01	54	LBUSA01
55	LBUSC00	56	LBUSA00
57	-5.2V	58	GND
59	GND	60	BECLTRG1
61	CLK10-	62	-2V
63	CLK10+	64	BECLTRG0

**Figure A-5. P2 Pin Configuration**



**NOTES:**



**READER'S COMMENT FORM**

Your comments assist us in improving the usefulness of C&H's publications; they are an important part of the inputs used for revision.

C&H Technologies, Inc. may use and distribute any of the information that you supply in any way that it believes to be appropriate without incurring any obligation whatsoever. You may, of course, continue to use the information which you supply.

Please refrain from using this form for technical questions or for requests for additional publications; this will only delay the response. Instead, please direct your technical questions to your authorized C&H representative.

COMMENTS:

---



---



---



---



---



---



---



---



---



---

Thank you for helping C&H to deliver the best possible product. Your support is appreciated.

Sincerely,

F.R.Harrison  
President and CEO

## INSTRUCTIONS

In its continuing effort to improve documentation, C&H Technologies, Inc. provides this form for use in submitting any comments or suggestions that the user may have. This form may be detached, folded along the lines indicated, taped along the loose edge (DO NOT STAPLE), and mailed. Please try to be as specific as possible and reference applicable sections of the manual or drawings if appropriate. Also, indicate if you would like an acknowledgment mailed to you stating whether or not your comments were being incorporated.

NOTE: This form may not be used to request copies of documents or to request waivers, deviations, or clarification of specification requirements on current contracts. Comments submitted on this form do not constitute or imply authorization to waive any portion of the referenced document(s) or to amend contractual requirements.

\_\_\_\_\_ (Fold along this line) \_\_\_\_\_

\_\_\_\_\_ (Fold along this line) \_\_\_\_\_

Place Stamp Here
------------------------

\_\_\_\_\_  
\_\_\_\_\_  
\_\_\_\_\_

C&H Technologies, Inc.  
Technical Publications  
445 Round Rock West Drive  
Round Rock, Texas 78681